

**Keilrundschieber, Stahlguss /**  
**Gate valve, cast steel**  
**PA-031**

**Technische Daten**

**Bauform**

Keilrundschieber nach DIN 3352  
 PN 16  
 Außenliegende Spindel  
 Mit Handrad  
 Baulänge nach F5 (PN 10-25)  
 Gehäuse: 1.0619  
 Trim: 13% Cr

**Specification**

**Design**

Round body gate valve acc. to DIN 3352  
 PN 16  
 Outside screw and yoke  
 With handwheel  
 Face to face according to F5 (PN 10-25)  
 Body: 1.0619  
 Trim: 13% Cr

**Anschluss**

Flanschanschluss nach DIN

**Connection**

Flange connection according to DIN

**Betriebstemperatur**

Max. 400°C

**Operating temperature**

Max. 400°C

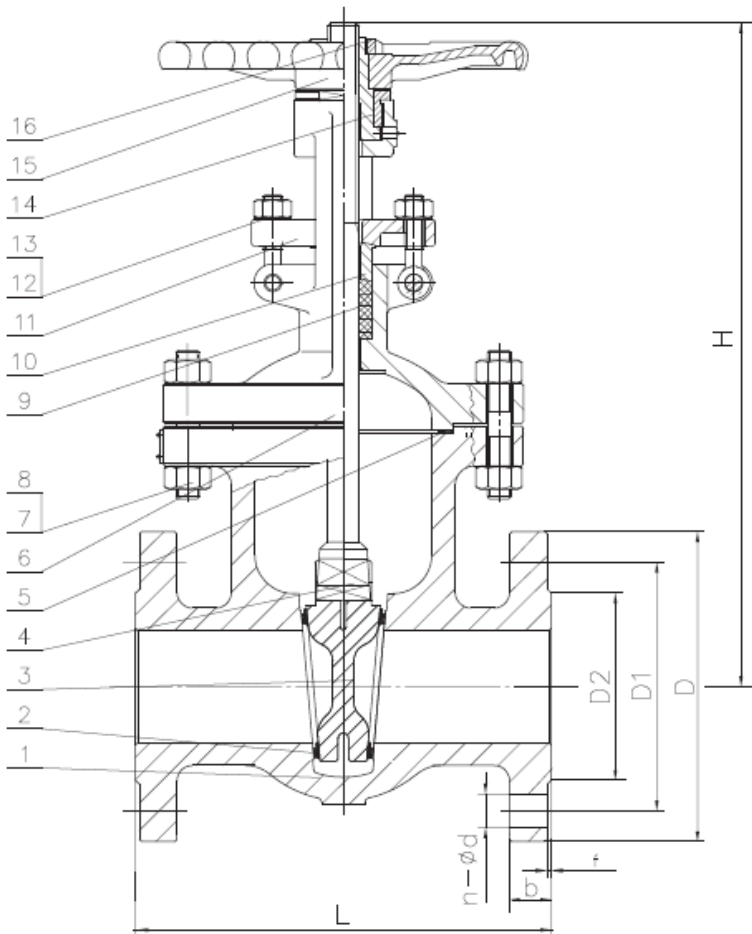

No.	Part Name	Material
1	Body	1.0619
2	Seat Sealing	13Cr
3	Wedge	1.0619 + 13Cr
4	Stem	ASTM A182 F6a
5	Gasket	SS304 + Graphite
6	Bonnet	1.0619
7	Bonnet Bolt	ASTM A193 B7
8	Bonnet Nut	ASTM A194 2H
9	Stem Packing	Graphite
10	Gland	ASTM A182 F6a
11	Gland Flange	1.0619
12	Gland Eyebolt	ASTM A193 B7
13	Gland Nut	ASTM A194 2H
14	Stem Nut	Copper Alloy
15	Handwheel	Ductile Iron
16	H.W. Lock Nut	ANSI 1020



DN	PN	D	b	D1	D2	f	n - Ød	L	H
50	16	165	18	125	102	3	4 - Ø18	250	350
65	16	185	18	145	122	3	4 - Ø18	270	380
80	16	200	20	160	138	3	8 - Ø18	280	400
100	16	220	20	180	158	3	8 - Ø18	300	450
125	16	250	22	210	188	3	8 - Ø18	325	520
150	16	285	22	240	212	3	8 - Ø22	350	600
200	16	340	24	295	268	3	12 - Ø22	400	750
250	16	405	26	355	320	3	12 - Ø26	450	910
300	16	460	28	410	378	4	12 - Ø26	500	1050
350	16	520	30	470	438	4	16 - Ø26	550	1200
400	16	580	32	525	490	4	16 - Ø30	600	1350
450	16	640	34	585	550	4	20 - Ø30	650	1450
500	16	715	36	650	610	4	20 - Ø33	700	1600
600	16	840	40	770	725	5	20 - Ø36	800	1900