

### Beschreibung

Design: DIN3840, BS EN 1868 Face to Face  
 Dimensions: DIN3202, BS EN 558-1  
 Flange Ends Dimensions: DIN2543, BS EN 1092-1  
 DIN2544, DIN2545, DIN2546, DIN2548  
 Test & Inspect: EN 10204-3.1, EN 12266-1

### Bestandteile

Part Name		Material				
1	Body	1.0619/WCB+CR13	1.0619/WCB +STL	1.0619/WCB +STL	DIN17445 1.4308	DIN17445 1.4408
2	Disc	1.0619/WCB +CR13	1.0619/WCB	1.0619/WCB +STL	DIN17445 1.4308	DIN17445 1.4408
9	Cover	1.0619/WCB	1.0619/WCB	1.0619/WCB	DIN 17445 1.4308	DIN17445 1.4408
3	Arm	1.0619/WCB	1.0619/WCB	1.0619/WCB	DIN17445 1.4308	DIN17445 1.4408
5	Pin	ASTM A182 F6a	ASTM A182 F6A	ASTM A182 F6a	ASTM A182 F304	ASTM A182 F316
6	Nut	ASTM A194 2H			ASTM A194 8	ASTM A194 8
7	Bolt	ASTM A194 B			ASTM A193 B8	ASTM A193 B8
4	Nut	ASTM A194 2H			ASTM A182 F304	ASTM A182 F316
8	Gasket	SS Spiral Wound W/graphite, or SS Spiral Wound E, or Reinforced PTFE W/PTFE				

**Die oben angegeben Werkstoffe können auch gemäß Kundenwunsch angepasst werden. Hierzu wenden Sie sich bitte an unsere technische Abteilung. Änderungen vorbehalten!**

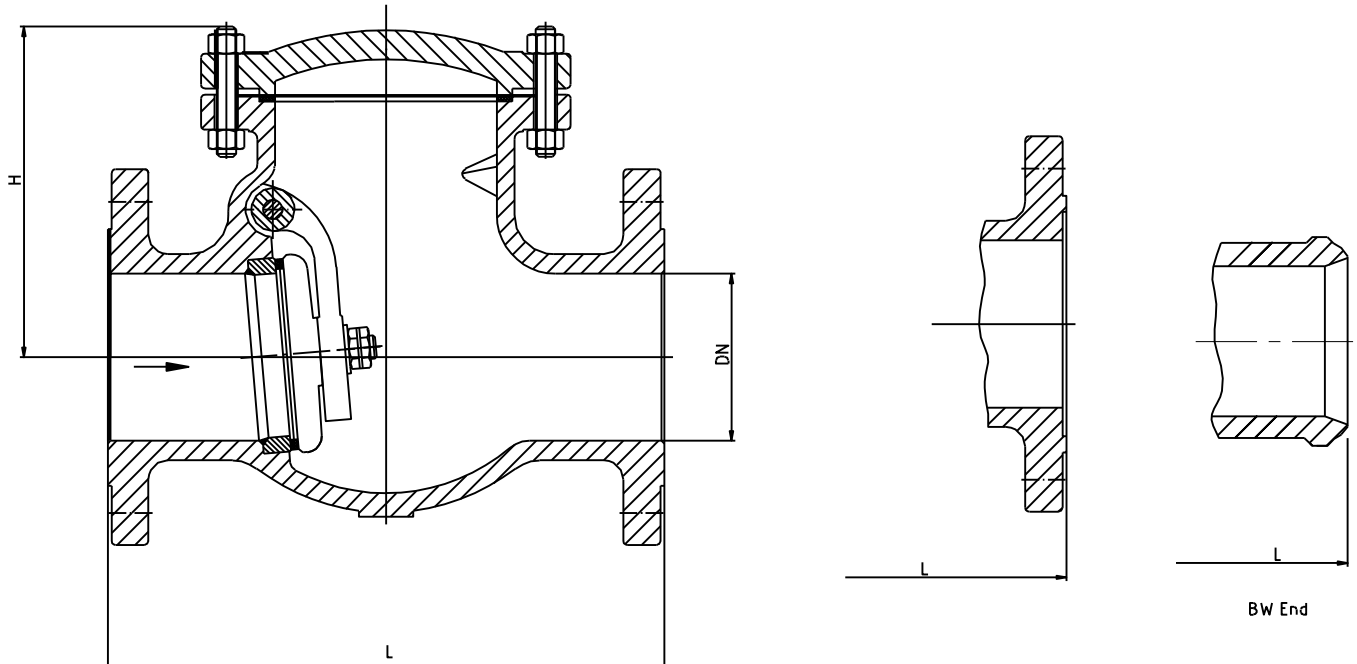

Dimensions																		
PN63 (DIN 3202-F2)																		
DN	40	50	65	80	100	125	150	200	250	300	350	400	450	500	600	-	-	-
L	260	300	340	380	430	500	550	650	775	900	1025	1150	1275	1400	1600	-	-	-
H	168	175	192	225	280	2108	335	390	452	520	570	626	695	770	905	-	-	-
W(Kg)	40	48	62	80	114	187	214	329	418	640	911	1130	1320	1693	2015	-	-	-

**\*Die Baulänge der BW-Enden entsprechen der Baulängen der Flanschausführung.**