

Beschreibung

Design: DIN3840, BS EN 1868 Face to Face
 Dimensions: DIN3202, BS EN 558-1
 Flange Ends Dimensions: DIN2543, BS EN 1092-1
 DIN2544, DIN2545, DIN2546, DIN2548
 Test & Inspect: EN 10204-3.1, EN 12266-1

Bestandteile

Part Name		Material				
1	Body	1.0619/WCB+CR13	1.0619/WCB +STL	1.0619/WCB +STL	DIN17445 1.4308	DIN17445 1.4408
2	Disc	1.0619/WCB +CR13	1.0619/WCB	1.0619/WCB +STL	DIN17445 1.4308	DIN17445 1.4408
9	Cover	1.0619/WCB	1.0619/WCB	1.0619/WCB	DIN 17445 1.4308	DIN17445 1.4408
3	Arm	1.0619/WCB	1.0619/WCB	1.0619/WCB	DIN17445 1.4308	DIN17445 1.4408
5	Pin	ASTM A182 F6a	ASTM A182 F6A	ASTM A182 F6a	ASTM A182 F304	ASTM A182 F316
6	Nut	ASTM A194 2H			ASTM A194 8	ASTM A194 8
7	Bolt	ASTM A194 B			ASTM A193 B8	ASTM A193 B8
4	Nut	ASTM A194 2H			ASTM A182 F304	ASTM A182 F316
8	Gasket	SS Spiral Wound W/graphite, or SS Spiral Wound E, or Reinforced PTFE W/PTFE				

Die oben angegeben Werkstoffe können auch gemäß Kundenwunsch angepasst werden. Hierzu wenden Sie sich bitte an unsere technische Abteilung. Änderungen vorbehalten!

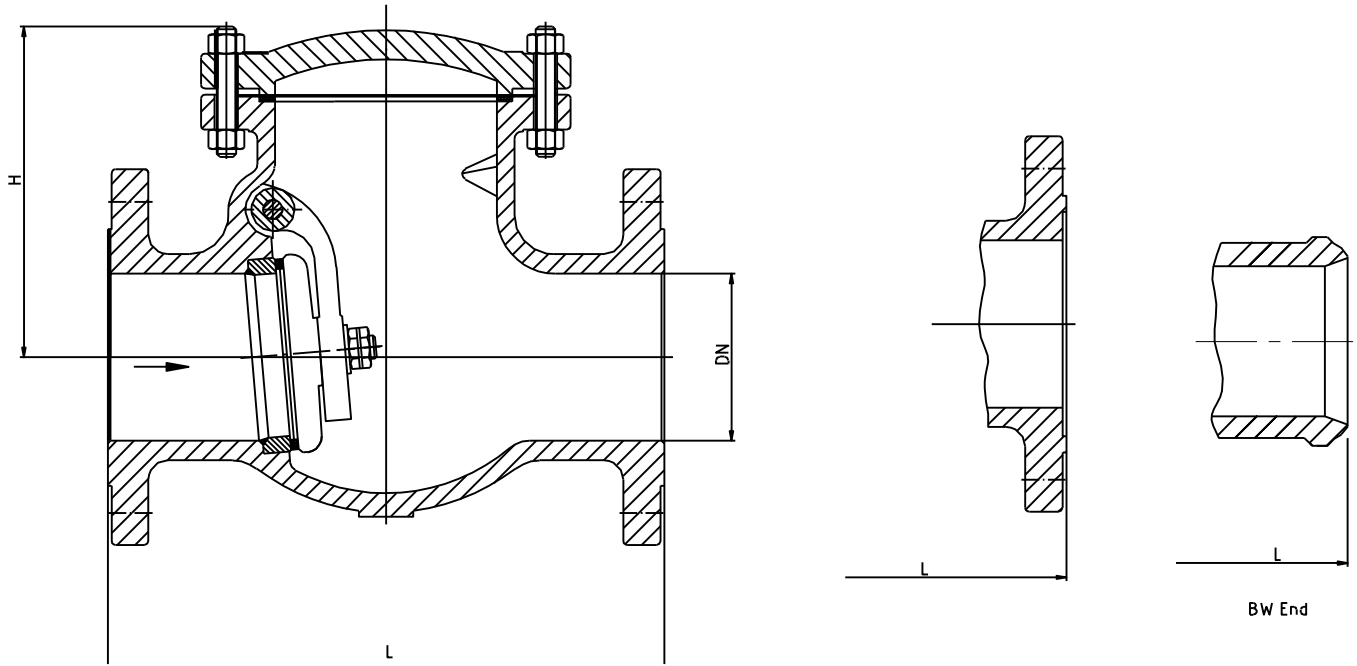

Dimensions																		
PN16 (DIN 3202-F6)																		
DN	40	50	65	80	100	125	150	200	250	300	350	400	450	500	600	700	800	900
L	180	200	240	260	300	350	400	500	600	700	800	900	1000	1100	1300	1500	1700	1900
H	129	147	161	178	190	265	285	345	394	420	455	520	565	610	740	895	1240	1450
W(Kg)	13	16	23	31	40	53	80	116	216	316	440	513	582	800	1158	1380	1540	1790

***Die Baulänge der BW-Enden entsprechen der Baulängen der Flanschausführung.**