

# Globe valve



## ◆ Cast steel globe valve design structure and feature

Design and manufacture conform to ASME16.34 & BS 1873, Test and check conform to API 598.

### ◆ Adopt the following structure

Taper sealing disc or soft sealing structure  
Self-centering gland or plate Renewable seat  
Bolted bonnet, spiral would eight-square gasket sealing  
bonnet or pressure seal bonnet

### ◆ According to the following standard

Flange ends conform to ASME B 16.5  
Butt-welding end conform to ASME B 16.25  
Face to face dimension conform to ASME B 16.10  
Operation type: electrical, pneumatic, hydraulic and gear drive etc

# Globe Valve

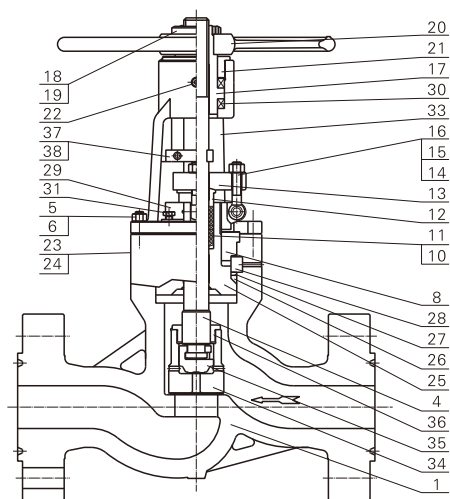

## Main parts material sheet

Item	Part name	WCB	WC6	WC9	CF8	CF3M	CE3MN
1	Body	A216 WCB	WC6	WC9	CF8	CF3M	CE3MN
4	Stem	A182 F6a	A182 F6a	A182 F6a	A182 F304	F316L	F53
5	Bolt	A193 B7	A193 B7	A193 B7	A193 B8	A193 B8M	A193 B8M
6	Nut	A194 2H	A194 2H	A194 2H	A194 8	A194 8M	A194 8M
8	Bonnet	A216 WCB	A216 WCB	A216 WCB	A351 Cf8	A351 Cf8	A351 Cf8
10	Packing	Flexible graphite	Flexible graphite	Flexible graphite	Flexible graphite	Flexible graphite	Flexible graphite
11	Distance ring	A182 F6a	A182 F6a	A182 F6a	A182 F304	F316L	F53
12	Packing gland	A182 F6a	A182 F6a	A182 F6a	A182 F304	F316L	F53
13	Packing plate	A216 WCB	A216 WCB	A216 WCB	A182 CF8	A182 Cf8	A182 Cf8
14	Eye bolt	A193 B7	A193 B7	A193 B7	A193 B8	Flexible graphite	Flexible graphite
15	Nut	A194 2H	A194 2H	A194 2H	A194 8	A194 8M	A194 8M
16	Pin	1035	1035	1035	304	304	304
17	Stem bolt	A439 D2	A439 D2	A439 D2	A439 D2	A439 D2	A439 D2
18	Locking nut	1035	1035	1035	1035	1035	1035
19	Locking screw	1035	1035	1035	1035	1035	1035
20	Hand wheel	AISI 1118	AISI 1118	AISI 1118	AISI 1118	AISI 1118	AISI 1118
21	Bearing gland	1035	1035	1035	1035	1035	1035
22	Oil cup	Finished product	Finished product	Finished product	Finished product	Finished product	Finished product
23	Nameplate	304	304	304	304	304	304
24	Rivet	AL	AL	AL	AL	AL	AL
25	Pressure seal seat	A216 WCB	A216 Wc6	A216 Wc9	Cf8	CF3M	CE3MN
26	Pressure seal gasket	304+flexible graphite	304+flexible graphite	304+flexible graphite	304+flexible graphite	304+flexible graphite	304+flexible graphite
27	Pressure seal ring	A182 F6a	A182 F304	A182 F304	A182 F304	A182 F316L	A182 F53
28	Segment ring	A182 F6a	A182 F11	A182 F22	A182 F304	A182 F316L	A182 F53
29	Hanger Roke	A216 WCB	A216 WCB	A216 WCB	CF8	CF8	CF8
30	Bearing	40Cr	40Cr	40Cr	40Cr	40Cr	40Cr
31	Hanger bolt	A193 B7	A193 B7	A193 B7	A193 B8	A193 B8	A193 B8
33	Roke	A216 WCB	A216 WCB	A216 WCB	CF8	CF8	CF8
34	Main disc	A105	A182 F11	A182 F22	A182 F304	A182 F316L	A182 F53
35	Auxiliary disc	A105	A182 F11	A182 F22	A182 F304	A182 F316L	A182 F53
36	Disc cover	1035	1035	1035	A182 F304	A182 F316L	A182 F53
37	Guide pad	1045	1045	1045	1045	1045	1045
38	Hex. Bolt	A193 B7	A193 B7	A193 B7	A193 B7	A193 B7	A193 B7

Note: the distance ring should be installed if user require

# Globe Valve

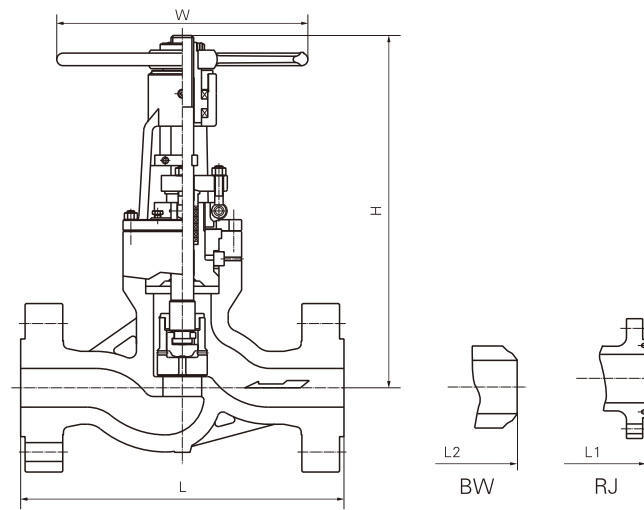

## CL2500

Spec (NAP)	in	2	2 1/2	3	4	6	8	10	12
Face to face(mm)	<b>L</b>	451	508	578	673	914	1022	1270	1422
	<b>L2</b>	279	330	368	457	610	762	914	1041
	<b>L1</b>	454	524	584	683	927	1038	1292	1444
Center height(mm)	<b>H</b>	495	495	603	685	971	1200	1416	1524
Hand wheel diameter(mm)	<b>W</b>	406	406	406	406	711	914	1066	1066
Weight (Kg) weld		74	74	114	140	459	767	1320	1905
Weight (Kg) flange		117	117	195	260	770	1238	2222	3310