

Beschreibung

Design und Herstellung: DIN3352 ,BS EN 1984
 Baulänge: DIN3202 ,BS EN 558-1
 Flanschenden: DIN2543, EN 1092-1
 DIN2544, DIN2545, DIN2546
 Test & Inspektion: EN 10204-3.1 , EN 12266-1

Standard material specifications

Part Name	Material					
	Trim 1	Trim 8	Trim 5			
1 Body	1.0619/WCB+CR13	1.0619/WCB +STL	1.0619/WCB +STL	DIN17445 1.4308	DIN17445 1.4408	
2 Wedge	1.0619/WCB +CR13	1.0619/WCB +CR13	1.0619/WCB +STL	DIN17445 1.4308	DIN17445 1.4408	
7 Bonnet	1.0619/WCB +CR13	1.0619/WCB+CR13	1.0619/WCB +CR13	DIN17445 1.4308	DIN17445 1.4408	
9 Gland	ASTM A182 F6a			ASTMA182 F304	ASTM A182 F316	
10 Gland Flange	DIN17245 GS-C25			DIN17445 1.4308	DIN17445 1.4408	
3 Stem	ASTM A182 F6a			ASTMA182 F304	ASTM A182 F316	
4 Nut	A194 2H			A194 8	A194 8	
5 Bolt	A193 B7			A193 B8	A193 B8	
6 Gasket	SS Spiral Wound W/graphite, or SS Spiral Wound W/PTFE, or Reinforced PTFE					
8 Packing	Braided Graphite or Deformed Graphite Ring or PTFE					
11 Stem Nut	Copper alloy or A439 D2					
12 Hand Wheel	Ductile iron or Carbon steel					

Die oben angegeben Werkstoffe können auch gemäß Kundenwunsch angepasst werden. Hierzu wenden Sie sich bitte an unsere technische Abteilung. Änderungen vorbehalten!

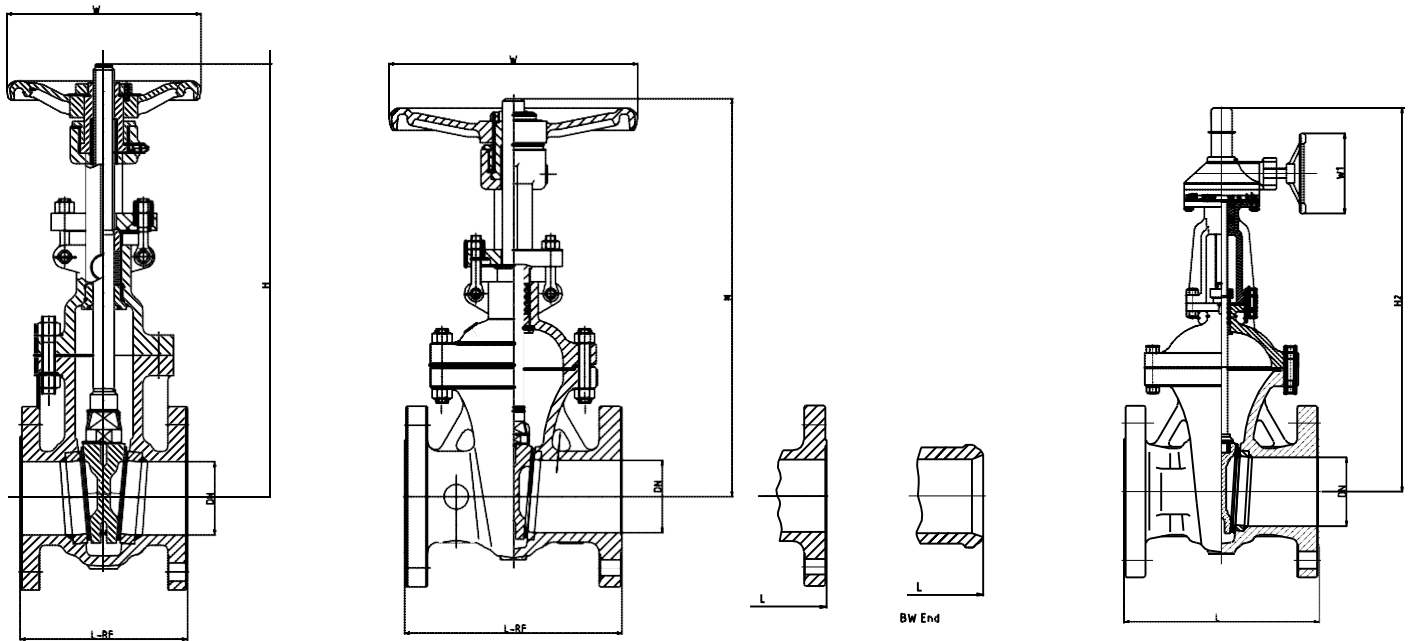

Dimensions																						
PN25 (DIN 3202-F5) EN 558-1 Grundreihe 15																						
DN	25	32	40	50	65	80	100	125	150	200	250	300	350	400	450	500	600	700	800	900	1000	1200
L-RF	160	180	240	250	270	280	300	325	350	400	450	500	550	600	650	700	800	900	1000	1100	1200	1400
H	205	270	305	325	350	415	465	545	610	775	905	1020	1180	1300	1420	1585	1810	-	-	-	-	-
H1	-	-	-	-	-	-	-	-	-	-	1220	1370	1525	1755	1890	2135	2585	2945	3345	3750	4005	4830
W	160	180	200	200	250	250	250	280	300	350	400	450	500	500	600	600	700	-	-	-	-	-
W1	-	-	-	-	-	-	-	-	-	-	310	310	310	460	460	460	600	600	600	600	600	600
W(Kg)	11	16	18	25	30	42	56	76	108	182	280	352	495	652	925	1250	1560	2030	2558	3870	4960	7558

Erhältlich mit: pneumatischem Antrieb , Elektrischem Antrieb, Getriebe, BY-PASS Umführung , BW-Enden.....
 DN ≤ 40, Baulänge gemäß Grundreihe 1.

***Die Baulänge der BW-Enden entsprechen der Baulängen der Flanschausführung.**